

PERSONALIZED PLAQUE ASSEMBLY INSTRUCTIONS

CastAccents.com

MailBox Assembly Instructions

1-800-513-1695

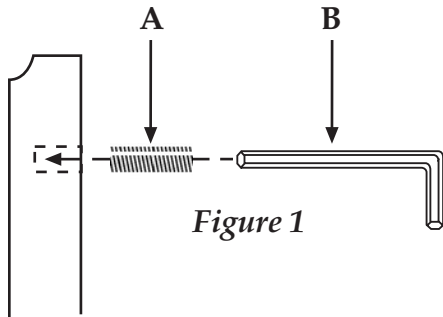

Figure 1

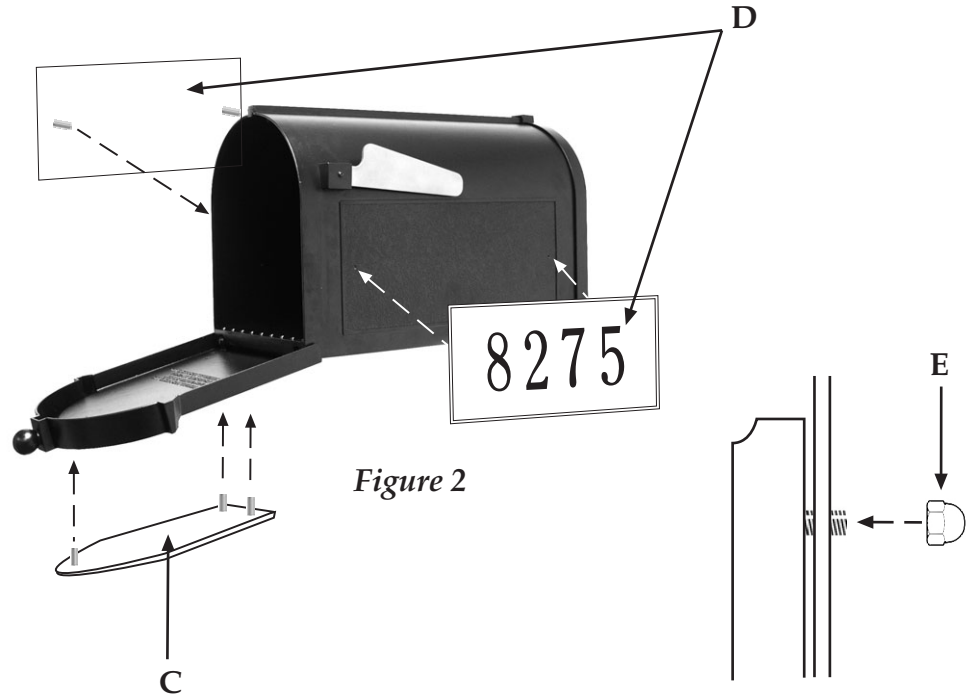

Figure 2

Figure 3

- A - Threaded Studs - 7
- B - Allen Wrench - 1
- C - Door Plaque - 1
- D - Side Plaques - 2
- E - Acorn Nuts - 7

WP04-004 © 2004 WHITEHALL PRODUCTS

Visit our Web Site at: www.whitehallproducts.com

AW-341

To attach your Personalized Address Plaques to your Whitehall Mailbox:

- 1) Locate screw position marks on side of mailbox body and on inside of door panel.
- 2) Drill holes through the mailbox walls with No. 7 or 3/16" drill.
- 3) Insert threaded studs (A) into the back side of the door and side plaques. Tighten with allen wrench (B). (See Figure 1)
- 4) Position the side plaques (D) so the studs are pushed through the holes in the mailbox wall and the plaque is located within the border. (See Figure 2)
- 5) Repeat Step 4 for the door plaque (C). (See Figure 2)
- 6) Using the acorn nuts provided (E), secure the plaques from the inside of the mailbox. (See Figure 3) (Pliers or a small socket wrench are helpful)

Cleaning Instructions:

Whitehall Mailboxes and Accessories are made of hand-cast aluminum with tough finishes to withstand exposure to the elements. To clean your Whitehall Product, use a non-abrasive detergent and water with a cloth, sponge, or soft brush. The simulated weathered bronze cannot be brightened by polishing. This hand-painted finish should retain its finish for many years without special attention.

WP04-004 © 2004 WHITEHALL PRODUCTS

Visit our Web Site at: www.whitehallproducts.com

AW-341

MAILBOX CLASSIC POST ASSEMBLY INSTRUCTIONS

Before installing your classic Whitehall mailbox post, consult your local branch of the US post office for road setback requirement and height from roadbed or curb. Post is designed for a 40" average height from ground to base of mailbox.

A - Whitehall Mailbox - 1 (Sold Separately)

B - 40" Classic Post - 1

C - 1/4" Lag Bolts - 2

D - Tube of Silicon Sealer - 1

- 1) Purchase a 4" x 4" x 48" piece of treated lumber from your local lumber yard or home center.
- 2) From post office recommended road setback line add 9" and mark position on ground for front edge of post. (See Figure 1)
- 3) Place the 4" x 4" post into the hole so that the face of the post is at the marked line (See step 2) leaving at least 18" out of the ground. (See Figure 2)
- 4) Partially backfill the hole around the post. Using a level make sure the post is vertical.
- 5) Complete the back fill of the post hole packing the earth firmly. Recheck for vertical and adjust if necessary, then repack soil.
Note: For a more permanent installation you may use concrete mix to backfill the hole unless it is against local post office or county road commission guidelines.
- 6) Slide aluminum post (B) over the partially buried 4x4 with the two bolt holes positioned away from the road and the aluminum post resting on the ground. (See Figure 2)
- 7) Plumb the aluminum post to vertical and use 2 - 1/4" x 2" lag bolts provided (C) to secure aluminum post to treated post.
(See Figure 2 - drilling pilot holes in the wood may be necessary)
Please Note: Apply small amount of Silicon Sealer (D) in and around holes before securing the two bolts to the post.

Figure 1

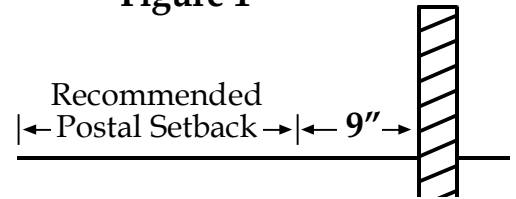
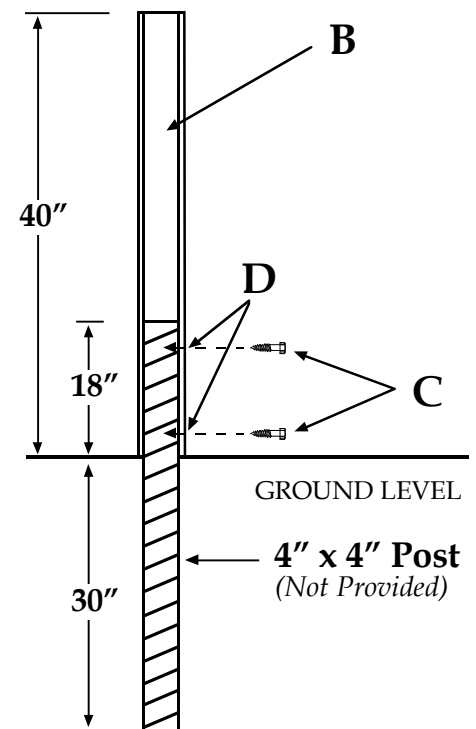

Figure 2



Attaching your mailbox to the classic post:

- 1) Apply a small amount of Silicon Sealer (D) around the inside and outside of the center mounting hole of your Mailbox. (See Figure 3)
- 2) Set mailbox onto the post, positioning the locators on the base of the mailbox **INSIDE** the post.
- 3) Reach inside the mailbox and place the large bolt (provided) in the large center hole in the base plate of the mailbox. (See Figure 3)
- 4) Thread in by hand and use a Philips head screwdriver to tighten the box to the post.

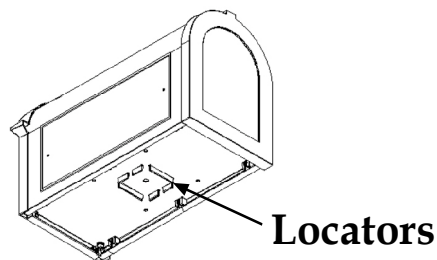
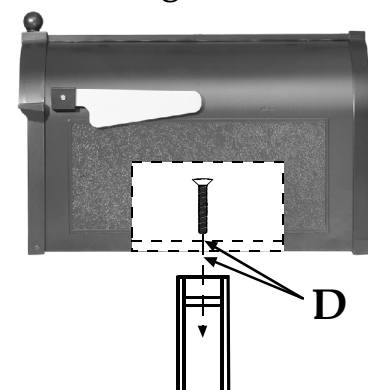

Figure 3



MAILBOX DELUXE POST ASSEMBLY INSTRUCTIONS

Before installing your deluxe Whitehall mailbox post, consult your local branch of the US post office for road setback requirement and height from roadbed or curb. Post is designed for a 40" average height from ground to base of mailbox.

A - Whitehall Mailbox - 1 (Sold Separately)

B - 54" Deluxe Post - 1

C - 1/4" Lag Bolts - 2

D - Mounting Brackets - 2

E - 10/24 x 1/2" Panhead Screws - 8

F - Finial - 1

G - Tube of Silicon Sealer - 1

*** - Set Screw - 1**

*** - Allen Wrench - 1**

- 1) Purchase a 4" x 4" x 48" piece of treated lumber from your local lumber yard or home center.
- 2) From post office recommended road setback line add 20.5" and mark position on ground for front edge of post. (See Figure 1)
- 3) Place the 4" x 4" post into the hole so that the face of the post is at the marked line (See step 2) leaving at least 18" out of the ground. (See Figure 2)
- 4) Partially backfill the hole around the 4" x 4" post. Using a level make sure the post is vertical.
- 5) Complete the back fill of the post hole packing the earth firmly. Recheck for vertical and adjust if necessary, then repack soil. *Note: For a more permanent installation you may use concrete mix to backfill the hole unless it is against local post office or county road commission guidelines.*
- 6) Slide aluminum post (B) over the partially buried 4x4 with the two bolt holes positioned away from the road and the aluminum post resting on the ground. (See Figure 2)
- 7) Plumb the aluminum post to vertical and use 2 - 1/4" x 2" lag bolts provided (C) to secure aluminum post to treated post. (See Figure 2 - drilling pilot holes in the wood may be necessary) *Please Note: Apply small amount of Silicon Sealer (G) in and around holes before securing the two bolts to the post.*
- 8) Apply small amount of Silicon Sealer (G) in and around holes on brackets (D) and attach to deluxe post (B) facing the street using 4 screws (E) provided. (See Figure 3) *DO NOT tighten screws until mailbox is attached. (if a double mailbox mount is being used, the road set back will be recommended postal set back plus 9", 2 sets of bracket are used and brackets are set parallel with the street)*
- 9) Place finial (F) over top of post (B) and, using a rubber mallet, tap finial down firmly on the post.

Attaching your mailbox to the deluxe post and brackets:

- 1) Apply a small amount of Silicon Sealer (G) in and around the 4 holes on top of the brackets (D). Place the mailbox (A) on top of the brackets (D) with the back of the box against the post (B) and the box centered over the brackets.
- 2) Using 4 screws (E) provided, reach inside the mailbox and place them thru the 4 holes and into the bracket (threaded holes) hand tighten. *(Loosening the brackets on the post may be necessary to get alignment. If so retighten the brackets to the post once the box is secure).*
- 3) Use a Phillips screwdriver to tighten the 4 screws.

* - The set screw and allen wrench are used to secure the finial to the post for the Superior and Sorrento Post packages only.

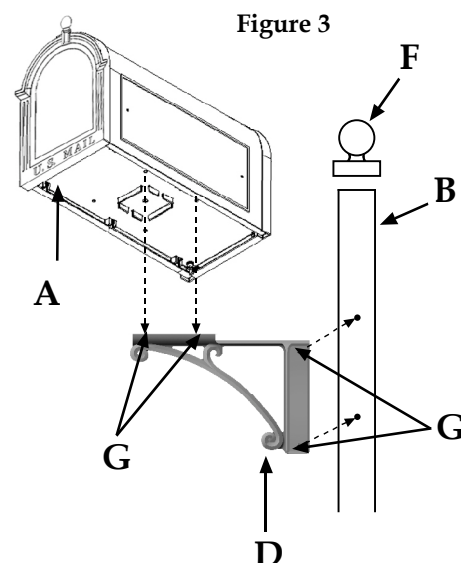
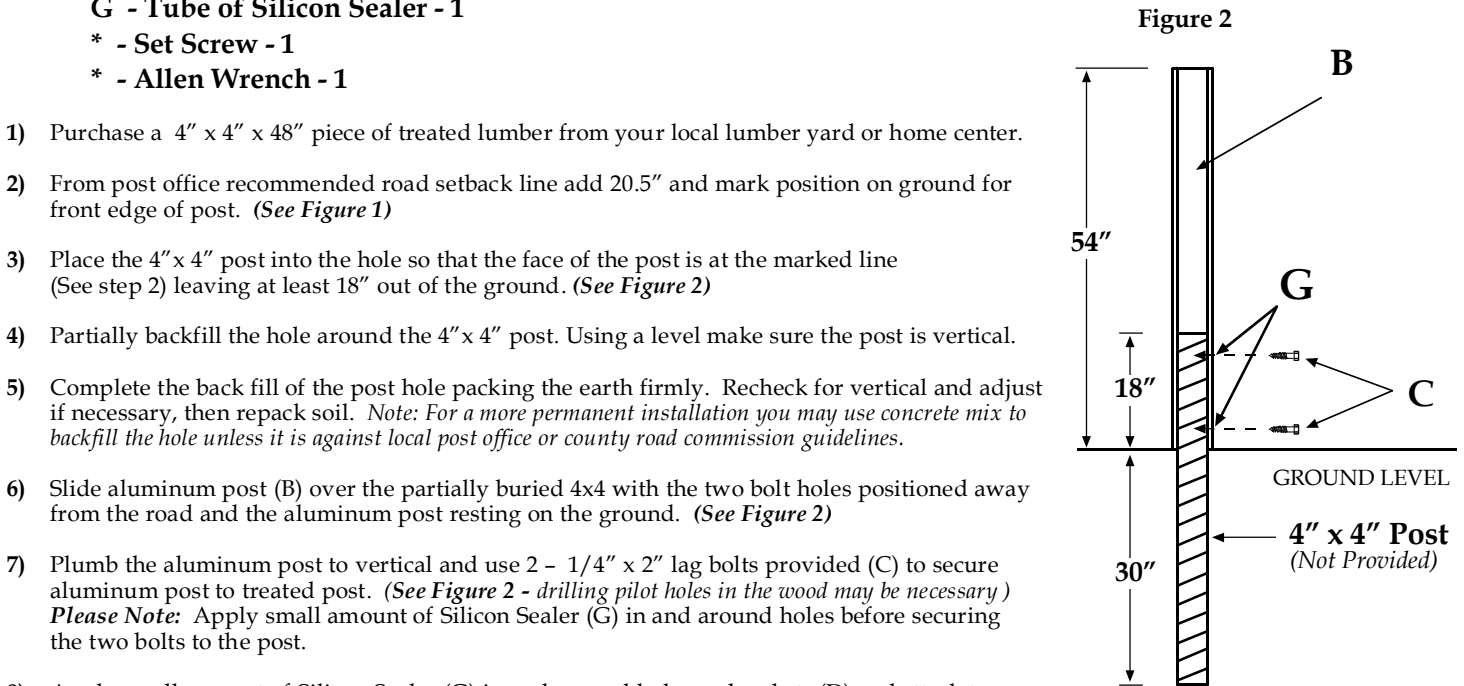
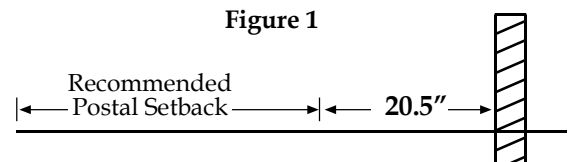

PERSONALIZED TOPPER ASSEMBLY INSTRUCTIONS

CastAccents.com

MailBox Assembly Instructions

1-800-513-1695

REMOVE



Figure 1

- A - Personalized Topper - 1
- B - 1 - 1/4" Threaded Studs - 2
- C - Allen Wrench - 1
- D - Cork Washers - 2
- E - Wing Nuts - 2

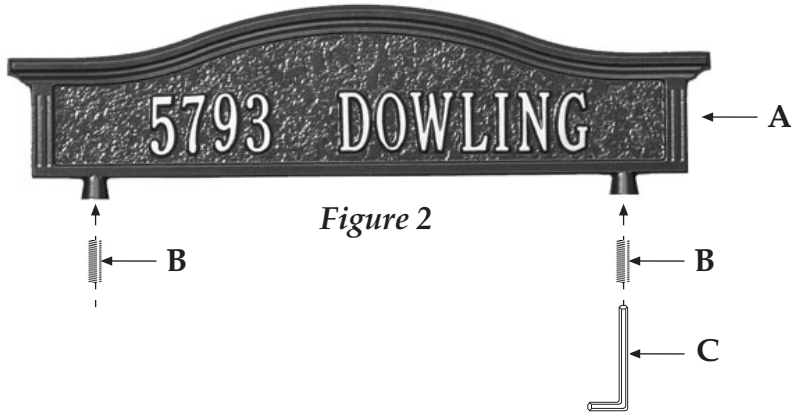

Figure 2

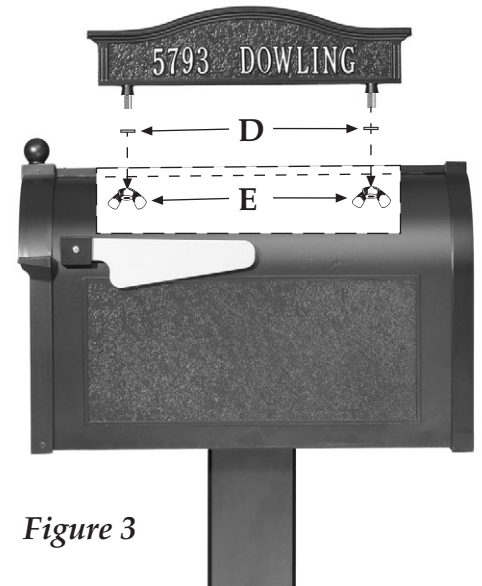

Figure 3

To attach your Personalized Address Topper to your Whitehall Mailbox:

- 1) Locate and remove two large screws on the top rib of the mailbox. *(See Figure 1)*
(To remove screws for topper mounting, take off nuts from inside the mailbox with pliers or a socket wrench. Tap out the screws from inside the mailbox with a hammer.)
- 2) Insert threaded studs (B) into the Topper legs (A). Tighten with allen wrench (C). *(See Figure 2)*
(Shorter studs may be used on other brand mail boxes)
- 3) Place Cork Washers (D) over the studs on the Topper plaque (A). *(See Figure 3)*
- 4) Position the Topper plaque (A) so the studs are pushed through the holes in the top rail of mailbox. *(See Figure 3)*
- 5) Using the wing nuts provided (E), secure the plaque from the inside of the mailbox. *(See Figure 3)*

Cleaning Instructions:

Whitehall Mailboxes and Accessories are made of hand-cast aluminum with tough finishes to withstand exposure to the elements. To clean your Whitehall Product, use a non-abrasive detergent and water with a cloth, sponge, or soft brush. The simulated weathered bronze cannot be brightened by polishing. This hand-painted finish should retain its finish for many years without special attention.